

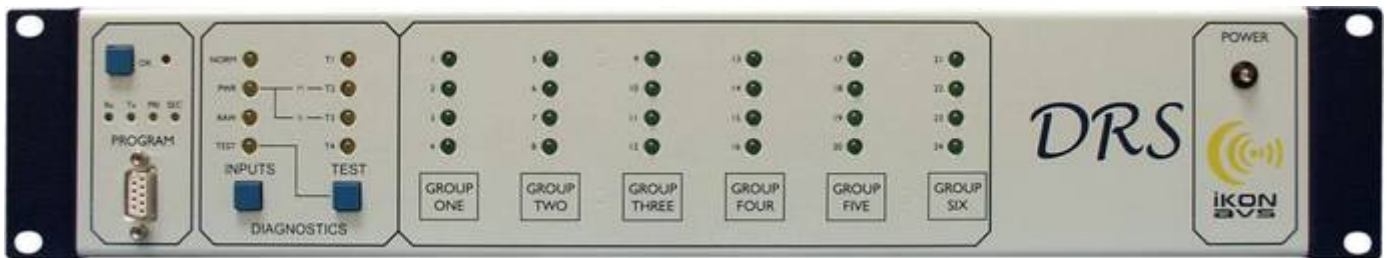

## DRS



### Description

An integral part of the IKON AVS fault monitoring network, the DRS will monitor up to twenty four external sensor inputs and report these locally as well as via a dual fibre network.

# Contents

<b>DESCRIPTION</b>	<b>1</b>
<b>CONTENTS</b>	<b>2</b>
<b>DRS INTRODUCTION</b>	<b>3</b>
<b>FUNCTIONALITY</b>	<b>4</b>
REAR PANEL CONNECTIONS	6
<i>Group Inputs</i>	6
<i>FUSE</i>	6
<i>Common Fault</i>	6
<i>Power Supply</i>	7
<i>Fibre Connectors</i>	7
<b>APPENDIX A</b>	<b>8</b>
UNIT AND INPUT DIAGNOSTICS	8
<i>RAW DATA</i>	9
<i>TEST Mode</i>	9
<b>APPENDIX B</b>	<b>11</b>
RS232 CONNECTING DETAILS	11
<b>APPENDIX C</b>	<b>12</b>
INPUT DESCRIPTION	12
<i>Connections</i>	12
<i>Configuration</i>	14
SID/ JNR DRS SETTINGS	15
<i>Setting selector</i>	15
<i>Event input settings</i>	15
<b>APPENDIX D</b>	<b>16</b>
COMMON FAULT RELAY	16
<b>APPENDIX E</b>	<b>17</b>
POWER SUPPLY	17
DC POWER INLET	17
<b>APPENDIX F</b>	<b>18</b>
OPTICAL FIBRE CONNECTORS	18
<b>MANUFACTURERS INFORMATION</b>	<b>19</b>

## DRS Introduction

The DRS can monitor up to twenty four separate external circuits and features:-

- Twenty-four inputs in six groups of four.
- Inputs suitable for 12V, 24V, Open Collector and Volt Free operation.
- Mains and DC operation.
- Common fault output.

Front panel indicators confirm the current status of the connected inputs whilst the comprehensive diagnostics ease external input and DRS testing.

It is used in conjunction with **SID** or **JNR** as part of an IEC 60849 compliant system to monitor:-

- Status of external UPS.
- DSP watchdog outputs.
- External relay & alarm circuits.
- Third party, non-networked VA equipment.

A windows based software utility is available for use with the unit allowing simple system configuration and adjustments. The software allows unit identification, selection of monitoring type, configuration of the inputs and common fault output as well as monitoring of mains & DC supplies.

## Functionality

### Front Panel Controls [See Appendix A]

Front panel controls allow configuration of the unit and LED's display the current status of each individual circuit.

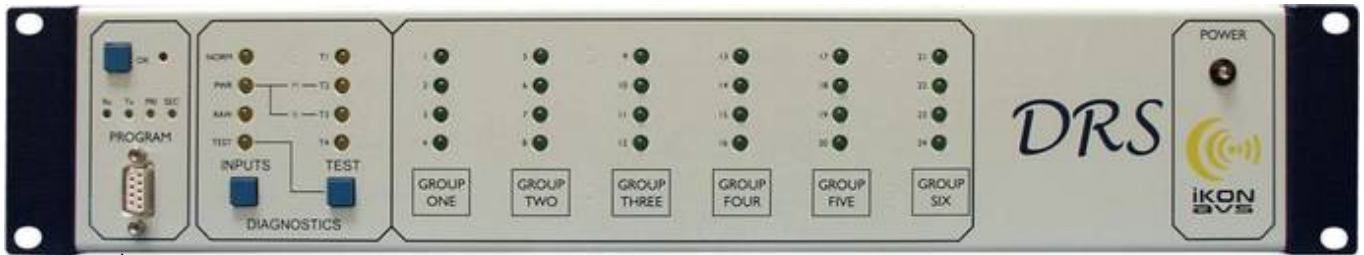

The **Rx** and **Tx** leds flash to confirm fibre communications.

The **PRI** and **SEC** leds indicate a fibre fault

The **OK** led flashes when any new fault is detected on the inputs, the units power sources or fibres and the common fault relay is de-energised.

Press the **OK** button and the led will illuminate continuously and the common fault relay is energised. I.e. OK= local fault acknowledge. When all faults are cleared the led goes out.

The 9 pin D socket is for configuring the unit using the supplied software. Refer to Appendix B for connection and software details.

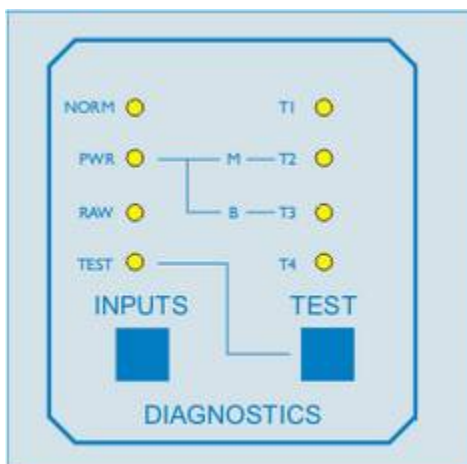

The Diagnostics section is used to test the units operation as well as derive additional information on the connected inputs.

Refer to appendix A for full details.

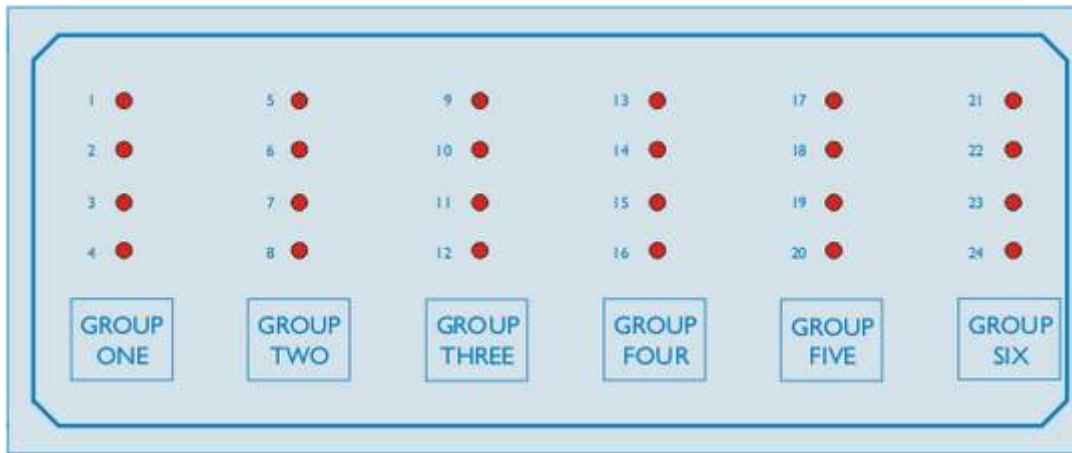
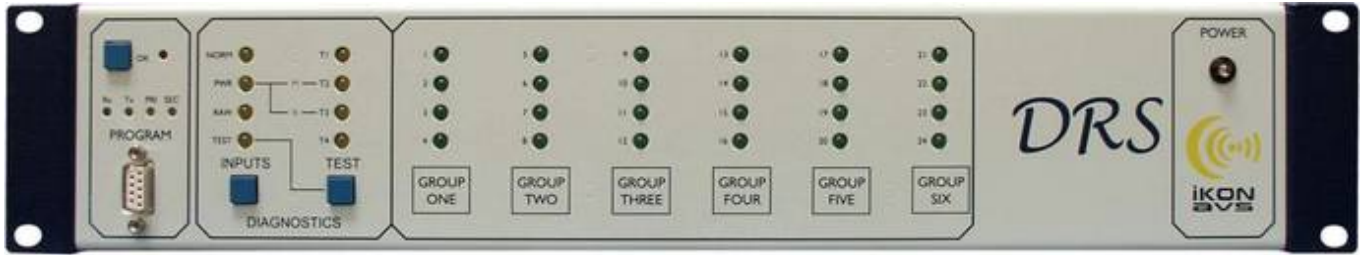

Inputs indicators are split into six groups, each representing a single input socket on the rear panel. The group name box is sized to allow the use of standard adhesive labels for ease of user identification.

During normal operation the input leds will be off when no fault is present. They will flash when a new fault occurs on the input with this changing to a steady ON state if the local OK button is pressed. When flashing the Common Fault relay is de-energised.

## Rear Panel Connections

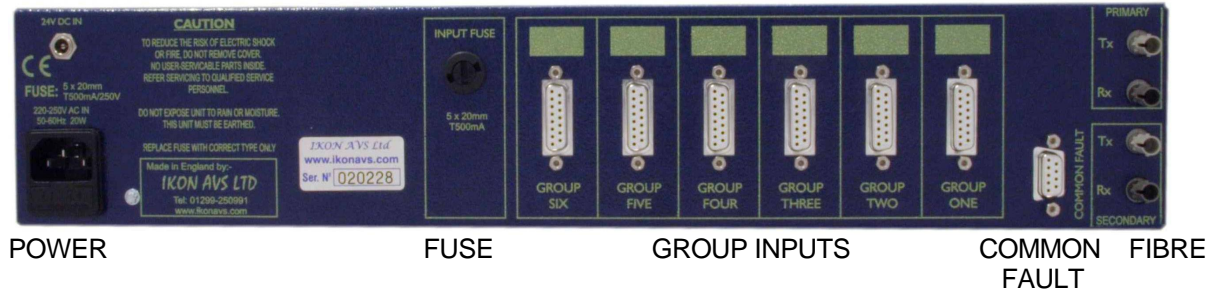

### Group Inputs

[See Appendix C]

Six sets of four inputs for the connection of external devices. Refer to Appendix C for full connecting and application details. Each input channel can be configured for an external input of 12V DC or 24V DC or can use the internal 12V DC power supply to allow external volt free or Open Collector connections to ground to be used.

Each group of four inputs is provided with a 15-Pin female Dee-type connector.

Pin 1	Input 1, +12V		Pin 9	Input 1, +24V
Pin 2	Input 2, +12V		Pin 10	Input 2, +24V
Pin 3	Input 3, +12V		Pin 11	Input 3, +24V
Pin 4	Input 4, +12V		Pin 12	Input 4, +24V
Pin 5	Input 1, -V		Pin 13	+12V out, 100mA max
Pin 6	Input 2, -V		Pin 14	
Pin 7	Input 3, -V		Pin 15	0V ( common )
Pin 8	Input 4, -V			

### FUSE

Provided for the protection of the internal power supply when using the 12V DC outputs. Replace fuse with correct type only ( 5 x 20mm T500mA ).

### Common Fault

[See Appendix D]

A change over relay provides a common fault output that can be configured to provide a change in status for any fault.

### ***Power Supply***

[See Appendix E]

A 230V 50Hz mains supply socket. The mains fuse (T500mA 20mm) is mounted within this socket. The fuse carrier also contains a spare fuse.

A 24V DC battery backup input is also provided. The software utility allows status monitoring of both power supplies.

### ***Fibre Connectors***

[See Appendix F]

Twin (primary & secondary) ST fibre connectors for incoming and outgoing fibre connections to other hardware in the system. The software utility allows either single or dual fibre operation with states of system verified and reported.

## Appendix A

### Unit and Input Diagnostics

The front panel Diagnostics section allows the verification of the units and any connected inputs status.

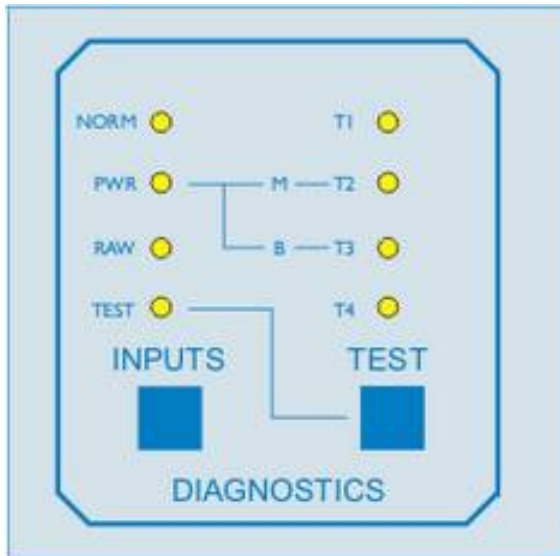

The **INPUT** switch cycles through display modes:-

- |             |            |  |
|-------------|------------|--|
| <b>NORM</b> | = Normal   | The unit is in normal operating mode.  |
| <b>PWR</b>  | = Power    | This displays the mains and battery input status on the adjacent test leds. T2 indicates that the mains input is OK and T3 that the battery input is OK.   |
| <b>RAW</b>  | = Raw Data | Allows the selection of one of three test modes selected by the <b>TEST</b> button that cycles the mode between T1, T2 and T3 as indicated by the leds above the Test button. See below for further explanation. |
| <b>TEST</b> |            | This display mode can only be entered into by the simultaneous pressing of both the <b>TEST</b> and the <b>INPUTS</b> button whilst in the RAW mode. See below for additional information.                       |

## **RAW DATA**

The individual channel status leds are software derived and can therefore be configured by the configuration utility to be either on or off when a fault condition exists.

Often to save power and enable rapid location of a fault the system is configured to only illuminate a led if the channel is in a fault state, this is totally independent of the network reporting of the fault. In some cases the system specification requires the opposite with indicators always on when OK and off when a fault.

Whilst both are accommodated within the DRS software it is often useful to be able to view the actual state of inputs both to assist initial set-up and subsequent fault finding.

Press the **INPUTS** button to cycle to **RAW**.

Now press the **TEST** button to cycle through the three test modes.

<u>MODE</u>	<u>LED</u>	<u>FUNCTION</u>
1	T1	Each channel led shows the real (raw) state of the input. If the opto isolator is ON (volts present or contact grounded) the channel led is ON.
2	T2	Shows which inputs are active, i.e. set-up for use using the configuration utility. If the led is on, its in use.
3	T3	Rescans the inputs and shows all current input faults.

## **TEST Mode**

To get to test mode select **RAW** mode using the **INPUTS** button and then press and hold **TEST** switch. Whilst pressing also press the **INPUTS** switch, then release both switches.

Pressing the **INPUTS** switch without the test switch will cause the **DRS** to skip the test mode and go back to normal mode.

Once in test mode all fault monitoring is disabled and the common fault relay is on. All network reported faults are cleared.

There are 12 test mode cycled through with the TEST switch. Mode is indicated in binary on the T leds. Tests are:-

<u>TEST</u>	<u>LEDS</u>	
1	T1	All groups leds OFF.
2	T2	All group leds ON. TEST and all other leds flashing.
3	T1,+T2	Common Fault relay ON. (No faults state)
4	T3	Common Fault relay FF. (Fault state)
5	T1+T3	Send 'Mains fail' message down network.
6	T2+T3	Send 'Battery fail' message down network.
7	T1+T2+T3	Report inputs 1+2+3+4 in fault condition down network. Group One leds flashing.
8	T4	Report inputs 5+6+7+8 in fault condition down network. Group Two leds flashing.
9	T1+T4	Report inputs 9+10+11+12 in fault condition down network. Group Three leds flashing.
10	T2+T4	Report inputs 13+14+15+16 in fault condition down network. Group Four leds flashing.
11	T1+T2+T4	Report inputs 17+18+19+20 in fault condition down network. Group Five leds flashing.
12	T3+T4	Report inputs 21=22+23+24 in fault condition down network. Group Six leds flashing.

## Appendix B

### RS232 Connecting Details

This is located on the front panel and provides a bi-directional RS232 port used to communicate with an IBM compatible PC or Laptop.

*Please note that the configuration software available is only PC compatible.*



- Pin 1 No connection
- Pin 2 Serial data receive (RX)
- Pin 3 Serial data transmit (TX)
- Pin 4 No connection
- Pin 5 Ground
- Pin 6 No connection
- Pin 7 No connection
- Pin 8 No connection
- Pin 9 No connection

## Appendix C

### Input Description

The DRS has six sets of four opto-isolated inputs for monitoring external events. When the DRS is networked to either a SID or JNR the events can be registered on an LCD display. All logged faults can then be printed or stored to a log file on a PC.

Each input channel can be configured for an external input of 12V DC or 24V DC or can use the internal 12V DC power supply to allow external volt free or Open Collector connections to ground to be used.

### Connectors

Each group of four inputs is provided with a 15-Pin female Dee-type connector.

Pin 1	Input 1, +12V		Pin 9	Input 1, +24V
Pin 2	Input 2, +12V		Pin 10	Input 2, +24V
Pin 3	Input 3, +12V		Pin 11	Input 3, +24V
Pin 4	Input 4, +12V		Pin 12	Input 4, +24V
Pin 5	Input 1, -V		Pin 13	+12V out, 100mA max
Pin 6	Input 2, -V		Pin 14	
Pin 7	Input 3, -V		Pin 15	0V ( common )
Pin 8	Input 4, -V			

### Connections

The diagrams below show how a voltage free or open collector contact should be wired using the internal 12V power supply.

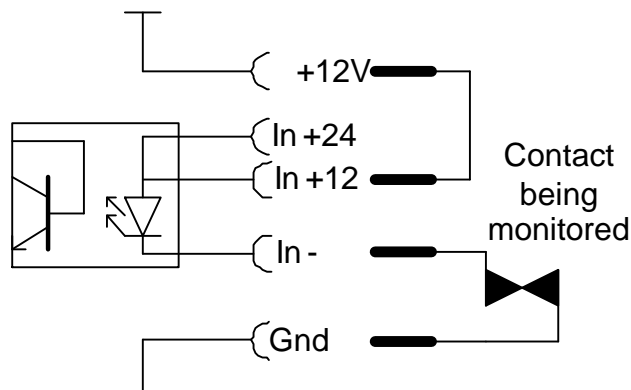

Alternative version using an external open collector rather than a volt free contact.

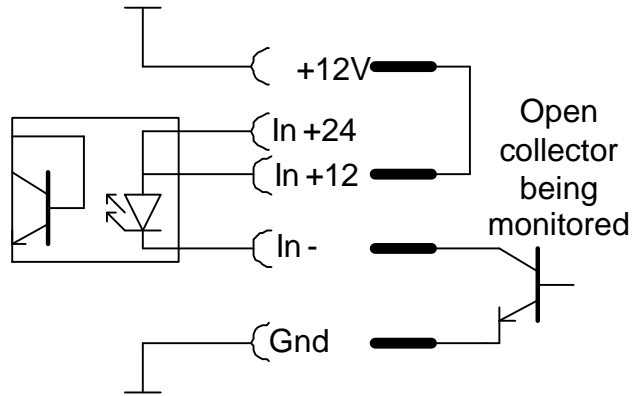

Using an external 12V DC power supply.

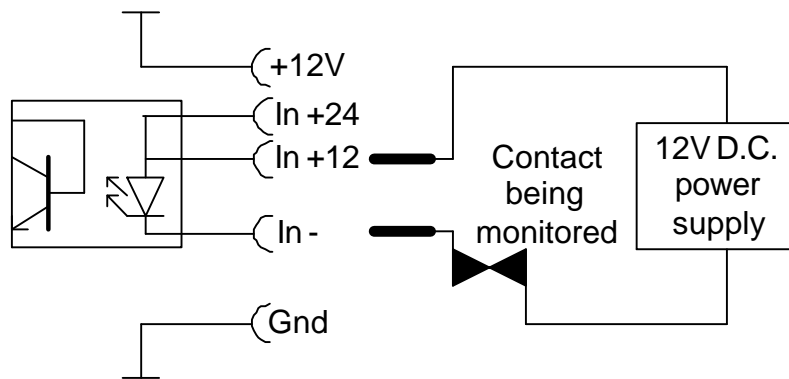

Using an external 24V DC power supply.

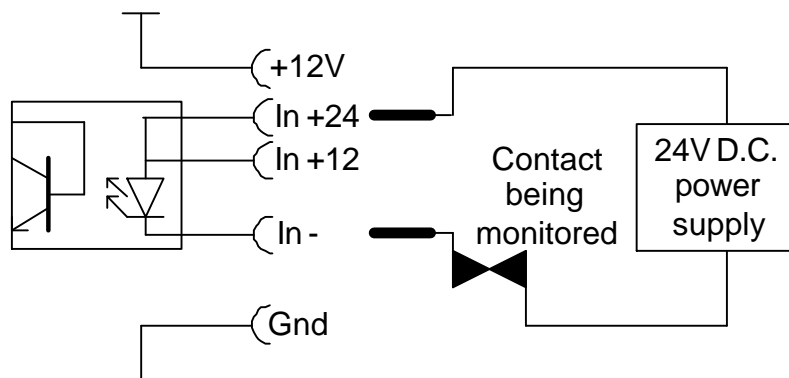

The Opto-diodes can be driven by **active** outputs as shown below

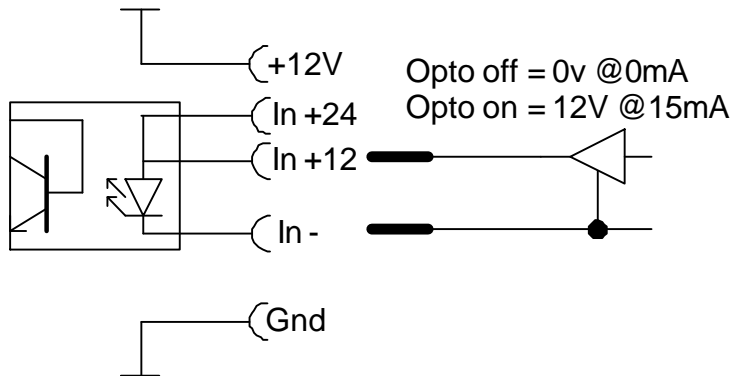

**N.B.** If an external supply or active drive is used, careful attention must be taken over ground routing.

### Configuration

Each input can be configured to operate in three modes :-

- ◆ Disabled.
- ◆ Fault when opto off.  
Fault reported when opto-coupler diode is un-powered and input OK when powered. This is the recommended mode of operation as a break in the wiring between the contact and the input will be reported as a fault.
- ◆ Fault when opto on.  
Inverse of above.

The status of these inputs is not latched, each input can be assigned an individual name for easy fault recognition.

Configuration is carried out using the SID/JNR Utility available from Ikon AVS Ltd.

## SID/ JNR DRS Settings

When running the utility and having added a DRS to the configuration, it can set up as follows.

### Setting selector

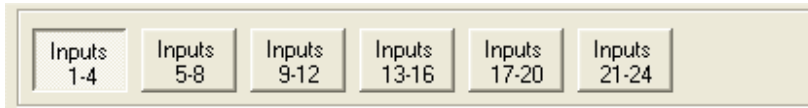

Selects which section of the DRS configuration is displayed and available for editing.

### Event input settings

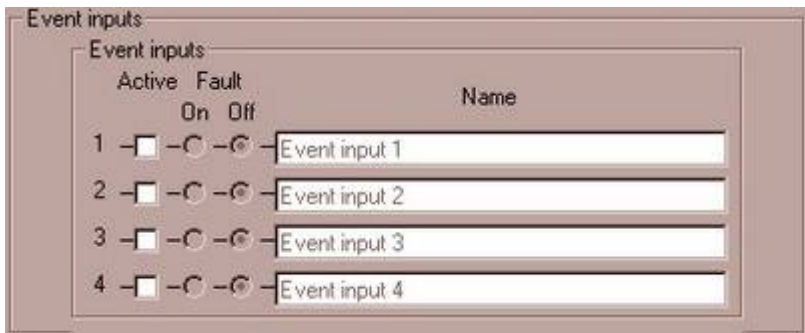

Displays the operating mode and details of each event input. These are

- Name. This is name that SID/JNR will display for this event input in any event reporting.

**Advise. Keep to 16 characters max for JNR and 20 characters for SID.**

- Active. When checked the event input will be used by the fault monitoring system. When unchecked the input is excluded from the fault reporting.
- Fault On/Off. When On is selected the system will report a fault when then event input opto is powered. When Off is selected the fault condition is reported when the event opto is unpowered.

## Appendix D

### Common Fault Relay

The common fault relay is activated on detection of any fault. It could be used to enable a sounder or light an indicator on detection of a fault, to alert an engineer of a fault on the system.



Pin 1 Relay Wiper  
Pin 2 NC when not in fault  
Pin 3 NO when not in fault  
Pin 4-9 No connection  
The contacts are rated @ 30V 1A

## Appendix E

### Power Supply

230V 50Hz, the mains fuse (T500mA 20mm ) is mounted within this connector. The fuse carrier also contains a spare fuse. To reduce the risk of fire replace the mains fuse only with the same type.

### DC power inlet

In the case of a mains supply failure the supply (24V $\pm$ 1V @1A) provided via this connector will be used instead. The plug is a standard D.C. connector with 2.5mm internal diameter, 5.5mm external and 14mm long. The central pin is the positive connection. The status of the D.C. input can be included in the fault monitoring.

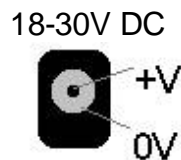

## Appendix F

### Optical Fibre Connectors

These are ST bayonet connectors operating at a wavelength of 820nm. The fibre length between units should not exceed 2km (with 2 couplers in line, i.e. for patch panels). To achieve the required fault tolerance twin fibres loops are used, these should be routed in physically divergent routes and opposite directions, as shown below.

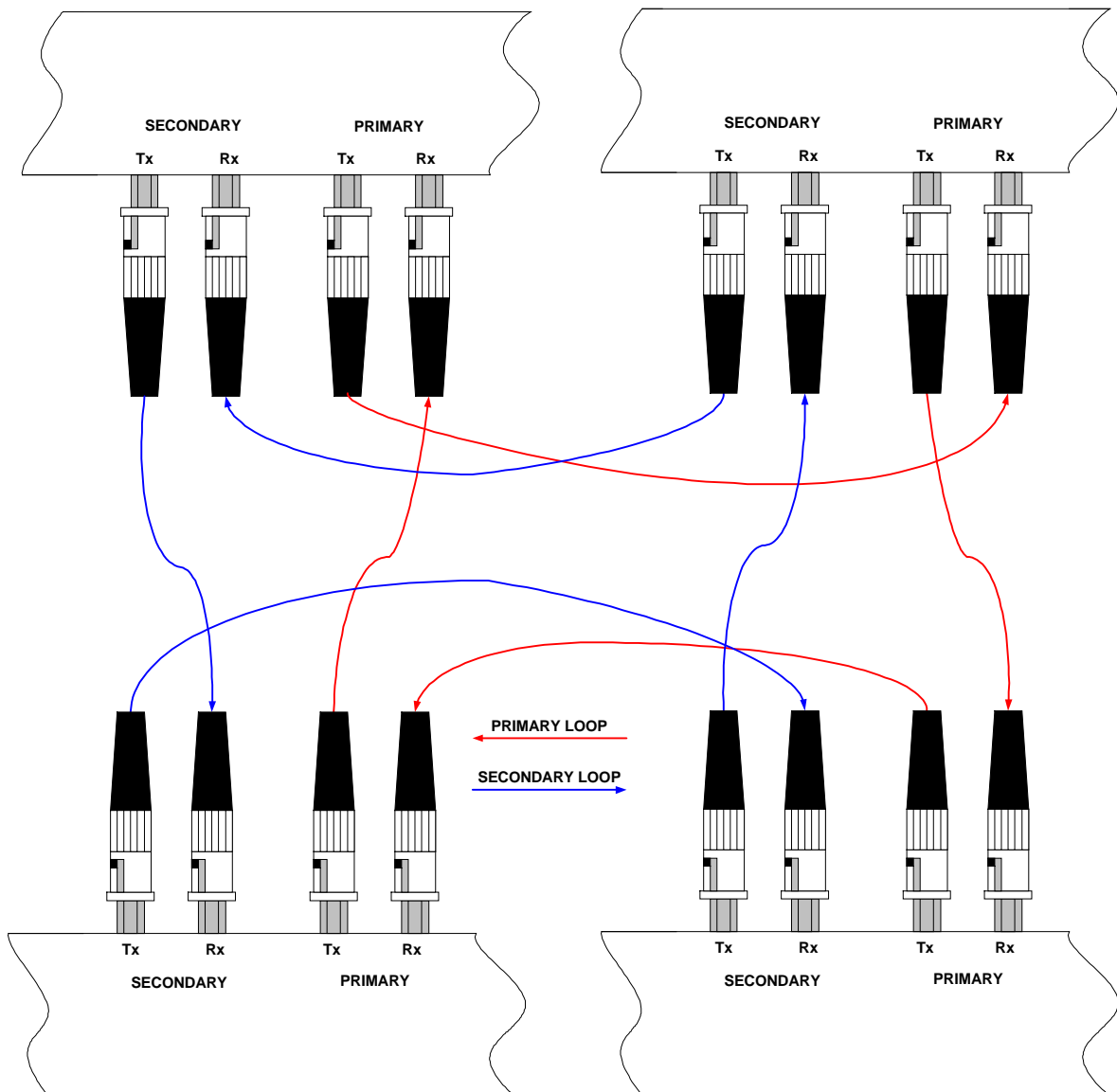

## Manufacturers Information

The DRS is manufactured in England by IKON AVS Ltd.

For service or warranty advice please initially contact your supplier. Alternatively contact the manufactures at:-

### **IKON AVS Ltd**

Unit 238 Ikon Trading Estate  
Droitwich Road  
Hartlebury  
Worcestershire  
DY10 4EU

Telephone: (44) 01299 250991

Fax: (44) 01299 250983

Website [www.ikonavs.com](http://www.ikonavs.com)

Technical support e-mail:- [support@ikonavs.com](mailto:support@ikonavs.com)

### **Electromagnetic Compatibility**

This equipment has been designed, manufactured and tested to conform to the European EMC directives EN55103-1 & EN55103-2 for classifications E2 and E4.

**Limitations as to use:**    **1.**    The specified equipment is to be mounted into an earthed, steel equipment rack and not mounted adjacent to RF transmitting or receiving equipment.